

# SURE-GRIP TOOL MOUNTS

## Heavy Rescue Tool Mounts

### PARTS AND INSTRUCTION MANUAL

#### MODELS:

**SG-VM-A-TTC HEAVY RESCUE TOOL MOUNT, CUTTER**

**SG-VM-A-TTS HEAVY RESCUE TOOL MOUNT, SPREADER/COMBI**

Keep your tools mounted safely with Ziamatic's Heavy Rescue Tool Mounts. These brackets are designed to store most extrication tools currently available. The Heavy Rescue Tool Mounts have been rigorously tested by receiving free falling weight drops of 60 pounds, over 100 times in a row to assure they will withstand the day to day use of firefighting.

- **High Density Polyethylene**
- **Non-corrosive, chemical resistant**
- **Designed to fit most brands of hydraulic and battery operated tools**
- **Can be flush-mounted or spaced from mounting surface to provide clearance for battery. Tested product was 5" from mounting surface using 3/8" hardware (not supplied)**



#### **Easy to use:**

##### **To Stow:**

**Simply place the jaws into the mount.**

**Secure the handle with the hook and loop strap.**

##### **To Deploy:**

**Pull the red tab to loosen the hook and loop strap and pull the tool out from the bracket.**



Scan for more information

Front View  
(Strap removed for clarity)

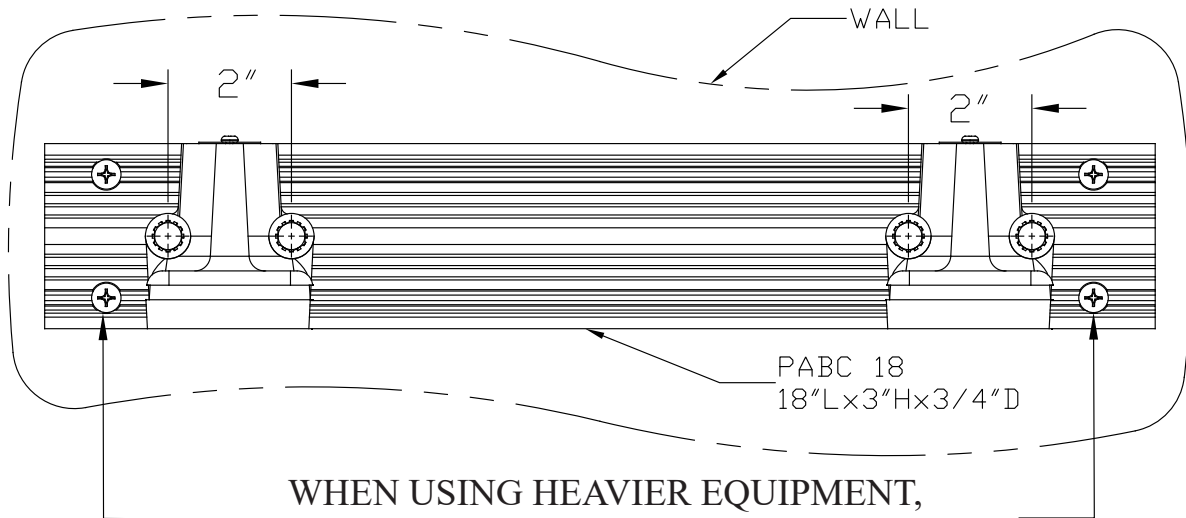

WHEN USING HEAVIER EQUIPMENT,  
We recommend the hardware securing the PABC-18  
be as close to the Sure-Grips as possible for  
maximum support

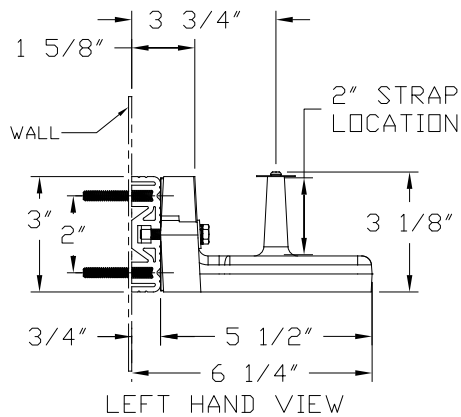
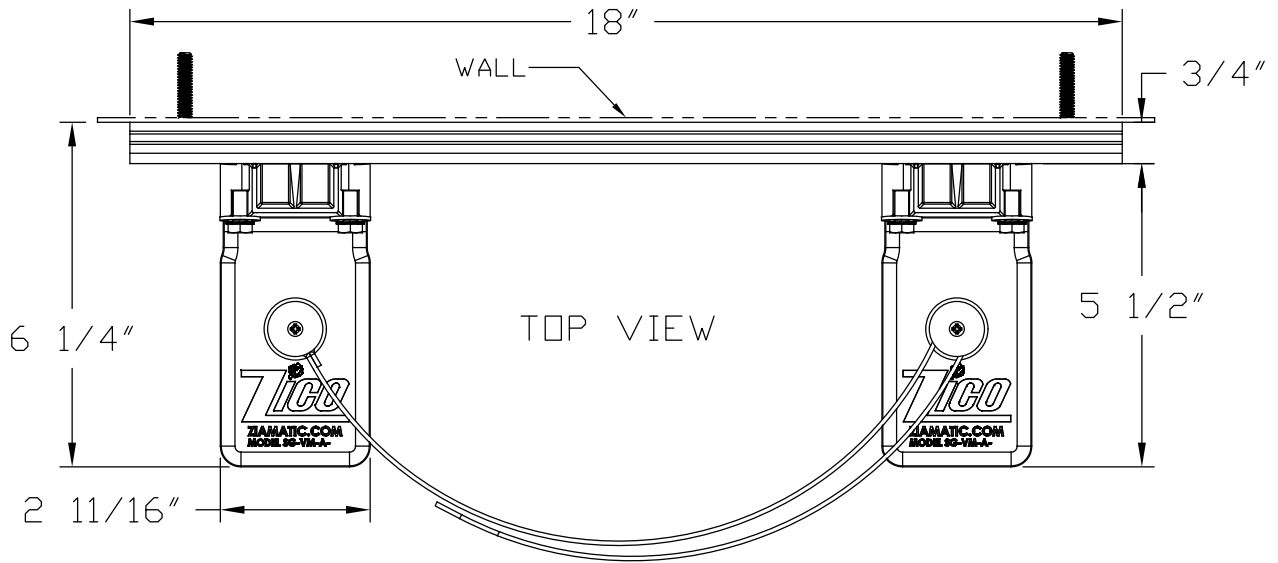

LEFT HAND VIEW  
(Strap removed for clarity)

Figure 1

**Model: SG-VM-A-1625**

**Adjustable Bracket with UMVS-1625-11 strap and Plastic Base Channel**

- See page 2 for dimensions

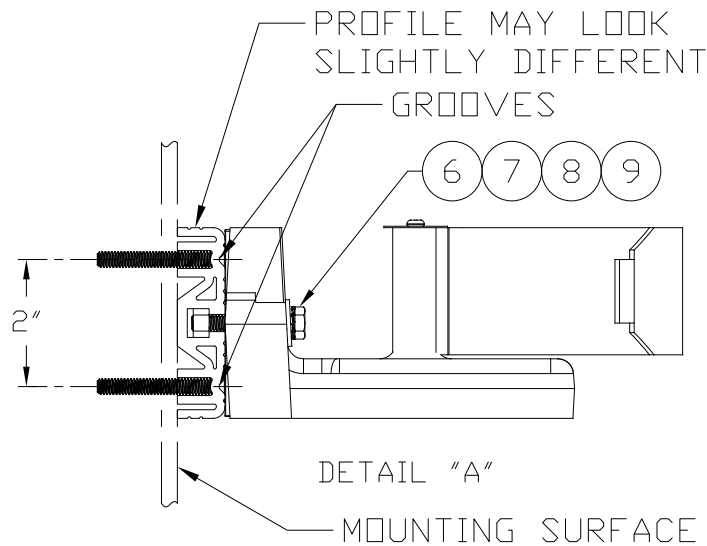
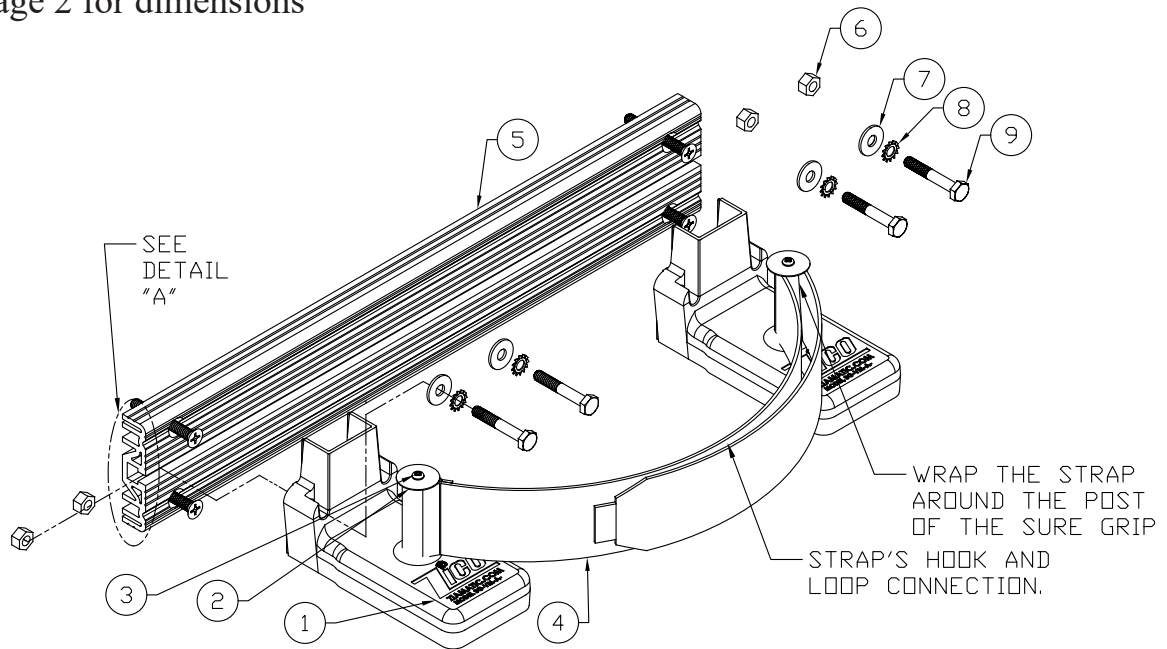

ITEM	PART NUMBER	DESCRIPTION	QTY
1	3085-530-101	BASE, SURE GRIP ADJUSTABLE	2
2	9114-161600	WASHER, FENDER, #8 X 1" S/S	2
3	9125-191306	SCREW, #6 X 3/8" PLASTIC THREAD CUTTING S/S	2
4	UMVS-1625-11	QUIC STRAP, 16" TO 25", ADJUSTABLE	1
5	PABC-18	PLASTIC BASE CHANNEL, 18"	1
6	9012-102500	NUT, HEX, 1/4-20 ZPS	4
7	9014-112500	FLAT WASHER, 1/4" ZPS	4
8	9014-252600	LOCK WASHER 1/4" EXT. TOOTH ZPS	4
9	9010-102526	SCREW, 1/4-20 X 1 5/8" HEX HD ZPS	4

**Model: QM-ET-TTC**

**Mount to flat surface with 3/8" flat head screws and nuts(not included)**

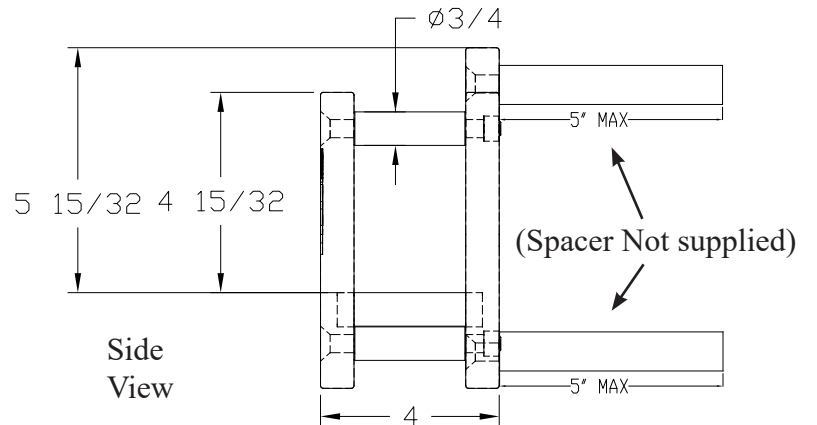
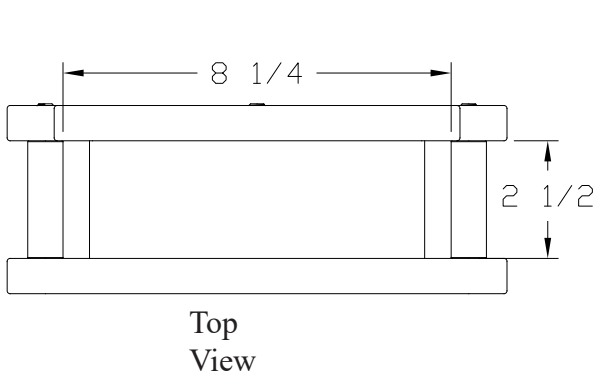
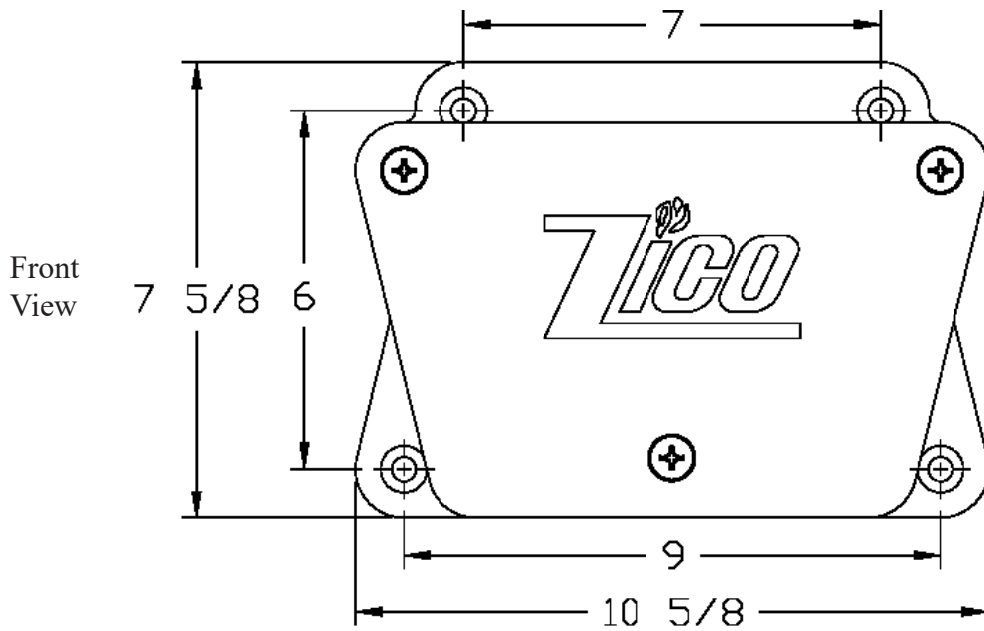
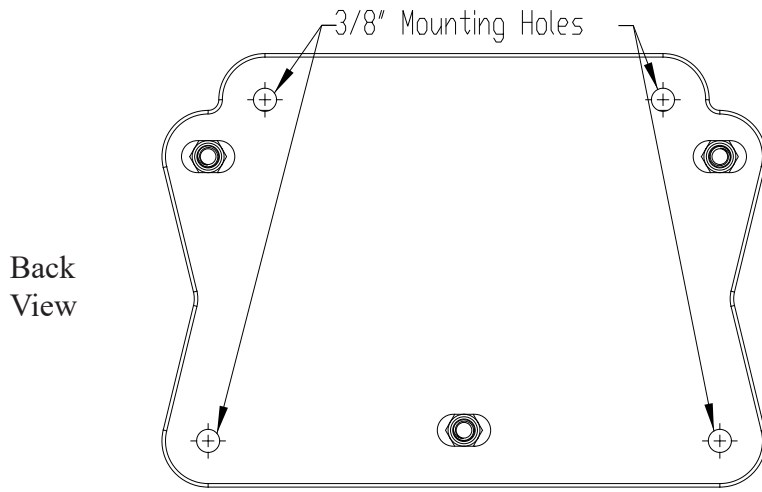

## Model: QM-ET-TTC

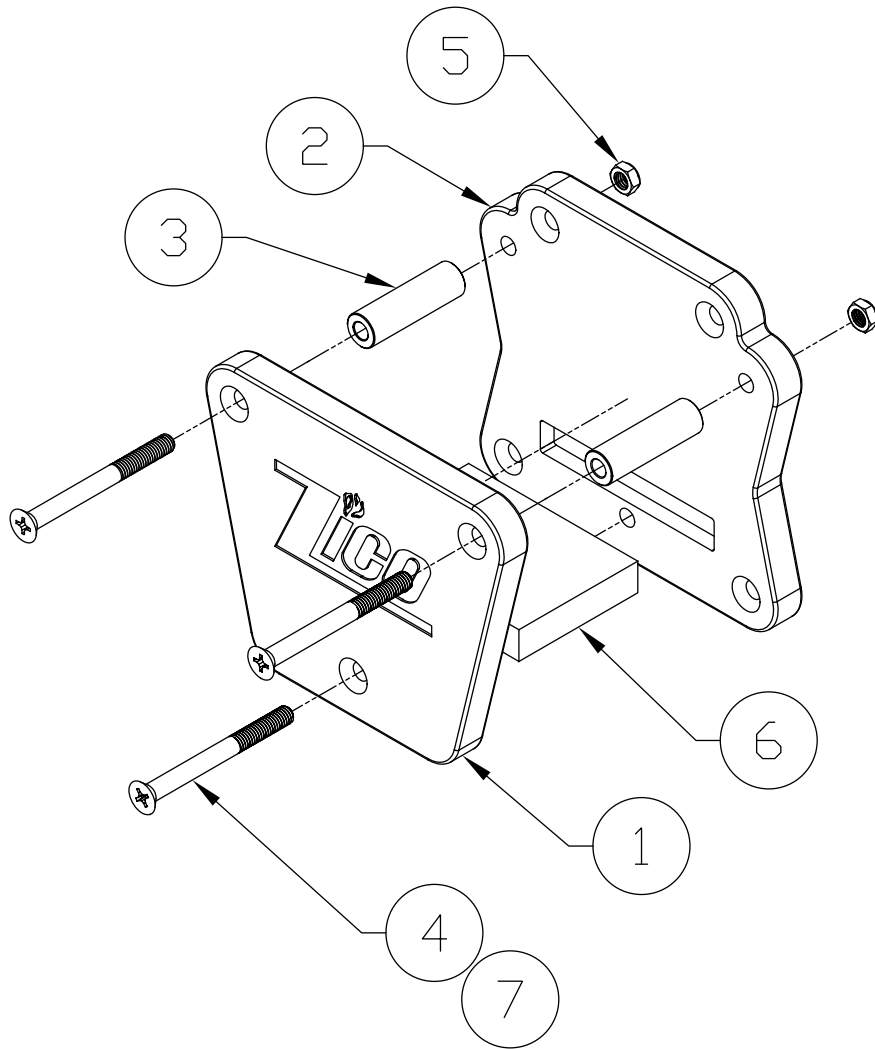

ITEM NO.	PART NO.	DESCRIPTION	QTY
1	3095-275-101	FRONT PLATE, QM-ET-TTC	1
2	3095-275-101	BACK PLATE, QM-ET-TTC	1
3	3095-270-105	SPACER, ALUMINUM	3
4	9010-163764	SCREW, 3/8-16 X 4 FH PHIL ZPS	3
5	9012-103700	NUT, 3/8-16 HEX, ZPS	3
6	3095-275-107	BASE PLATE, QM-ET-TTC	1
7		MEDIUM THREAD LOCK	A/R

# Model: QM-ET-TTS

Mount to flat surface with 3/8" flat head screws and nuts(not included)

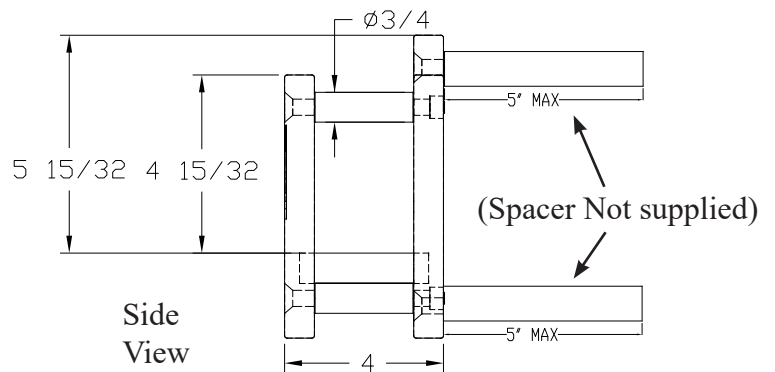
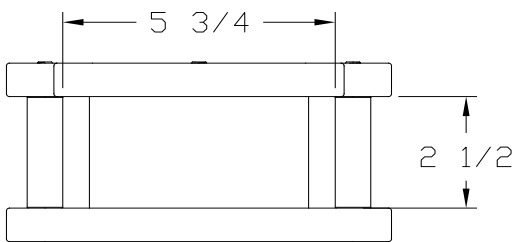
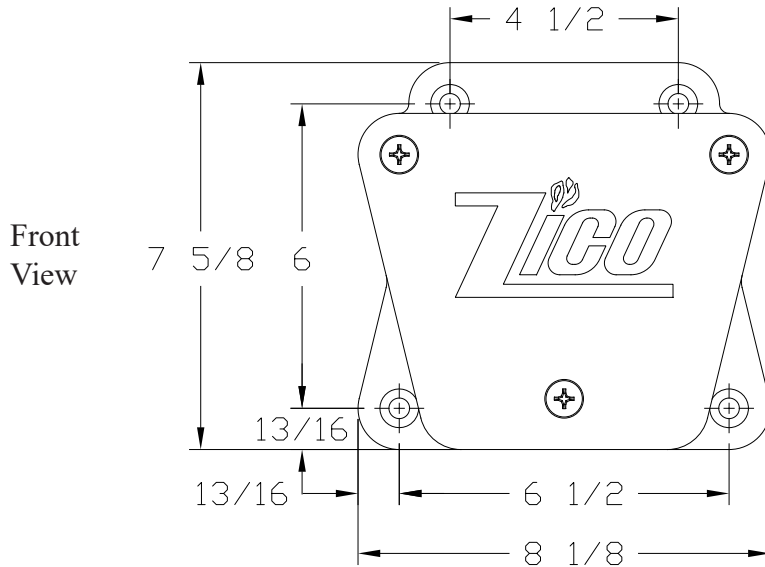
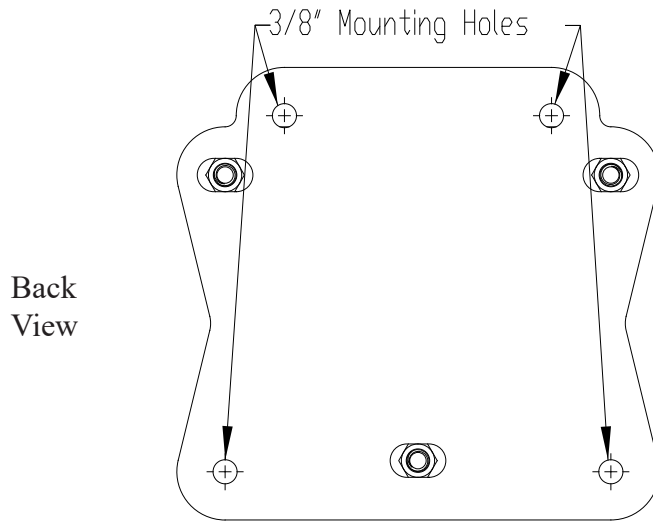

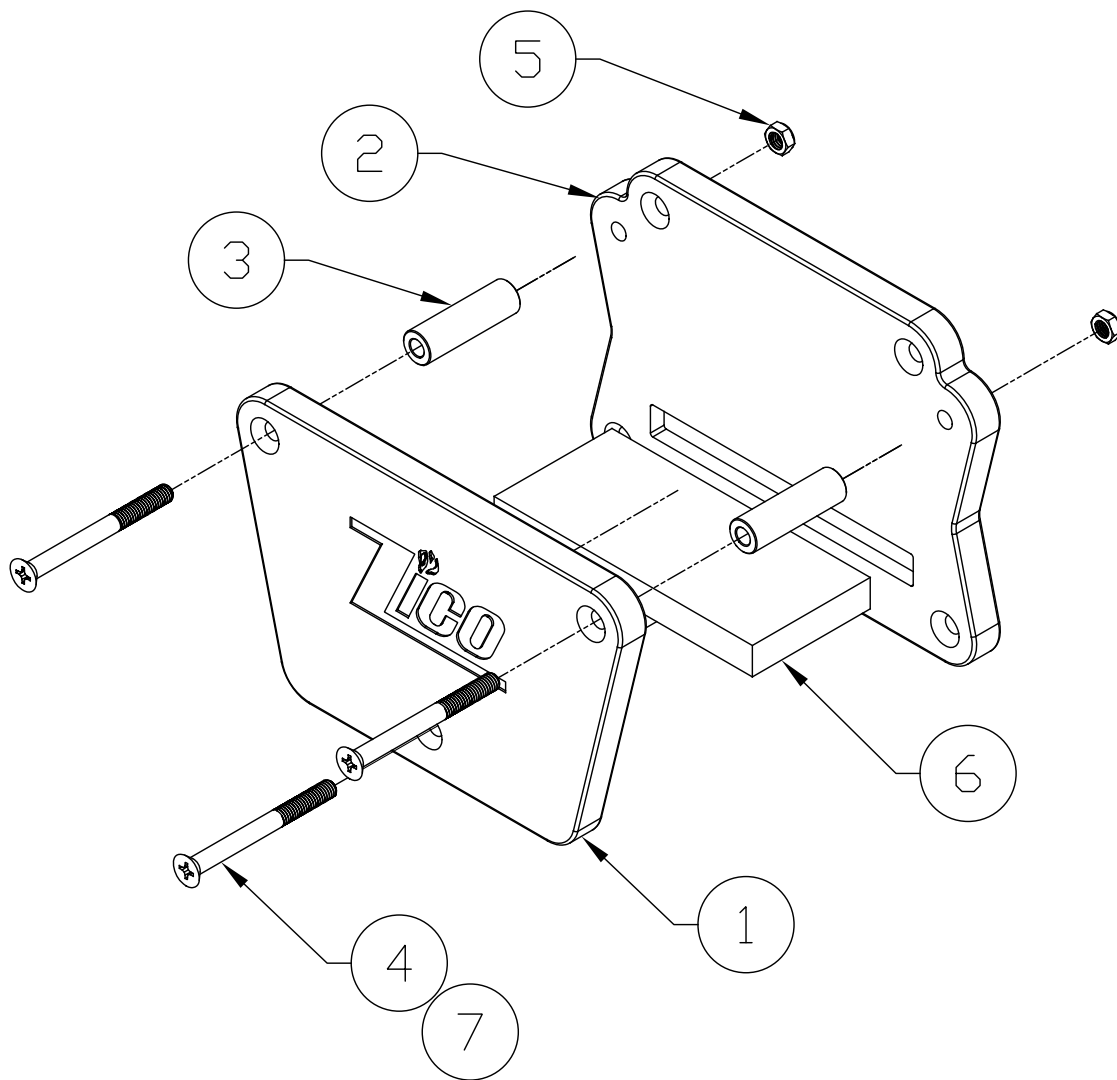

ITEM NO.	PART NO.	DESCRIPTION	QTY
1	3095-270-101	FRONT PLATE, QM-ET-TTS	1
2	3095-270-101	BACK PLATE, QM-ET-TTS	1
3	3095-270-105	SPACER, ALUMINUM	3
4	9010-163764	SCREW, 3/8-16 X 4 FH PHIL ZPS	3
5	9012-103700	NUT, 3/8-16 HEX, ZPS	3
6	3095-270-107	BASE PLATE, QM-ET-TTS	1
7		MEDIUM THREAD LOCK	A/R

*Item numbers shown in parentheses (.). See pages 3, 5 and 7*

Note: When selecting the mounting location, the weight of the tools to be secured should be taken into consideration, backing supports or other reinforcement may be required. Supports or reinforcement should be able to withstand the effort needed to remove the tool from the Sure-Grips.

## **I. Mounting:**

**Note:** We recommend the mounting hardware securing the PABC-18 be as close to the Sure-Grips as possible for maximum support.

**To Mount the OM-ET-TTC or OM-ET-TTS:** *See page 4 or 6*

1. Using the pattern shown on page 4 or 6, mark and drill four clearance holes for 3/8" hardware(not included).
2. The base mount may be spaced out from the surface a maximum of 5" for tool clearance(not Included).

**To mount the SG-VM-A-1625:** *See page 2 & 3*

1. Loosely fasten the Sure-Grips (1) to the PABC-18 (5) by using the supplied hardware as shown on Figure 1. Sure-Grips should be on the PABC-18 prior to compartment wall mounting for easier adjustment later. You may adjust the Sure Grips out of the way for clearance when mounting the PABC-18.
2. To mount the PABC-18 (5) to the vehicle, we suggest using Ø1/4" Flat Head Screws and associated hardware (not supplied). Drill and countersink a minimum of 4 holes using the grooves of the PABC-18 (holes should be located to align with compartment structure, reinforce where necessary). See Figure 1. **Note:** PABC-18 grooves are 2" apart for use with pegboards using 1" hole spacing. See Figure 1, Detail "A".
3. Position the Sure-Grips (1) to the width of the tool so that they contact the side of the equipment. Secure the Sure-Grips to the PABC-18.
4. The strap (4) can be changed for left-hand or right-hand use. To change the strap to the other side, remove the screw (3) and washer (2), slide the strap (4) off of the post of the Sure-Grip Adjustable (1) and secure to the opposite side.

## **II. Securing the Tool**

*Figure 2 shows how to properly secure the tool with the Adjustable Sure-Grips (1).*

1. Place the jaws of the into the Heavy Rescue Tool Mount.
2. Place and hold the tool handle against PABC-18 (5).
3. Place the Strap (4) across the tool.
4. Wrap the Strap around the post of the opposite Sure-Grip Adjustable (1).
5. While maintaining tension on the Strap, pull away from the Sure-Grip to tighten, then connect the hook and the loop of the Strap (4) to secure the tool.

## **III. Removing The Tool**

1. Grab the end of the Strap where the red tab is located.
2. Pull the strap away from the bracket/tool to release the hook and loop connection.
3. Pull the tool towards you, through the loosened strap and lift the jaws out of the lower mount. The Strap will free itself as you pull the tool towards you.



Figure 2  
Stowing Equipment

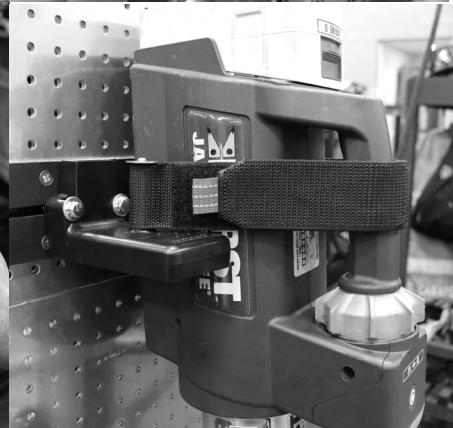
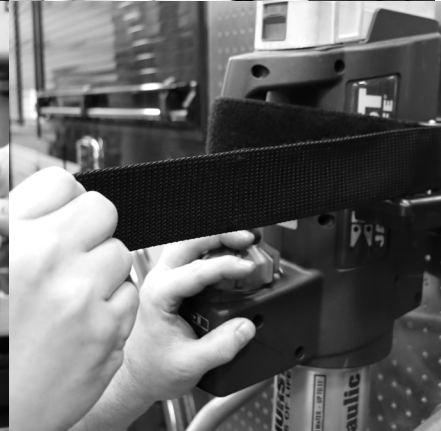

This page is blank intentionally

This page is blank intentionally



*Ziamatic Corp.*

10 West College Avenue, P.O. Box 337, Yardley, PA 19067-0587 • (215) 493-3618 • FAX: (215) 493-1401

[www.ziamatic.com](http://www.ziamatic.com)

TOLL FREE: 800-711-3473

\*ZICO is a registered trademark for fire, safety and marine products made by Ziamatic Corp.

Copyright Ziamatic Corp. 7-2023